

JOURNAL

The official magazine of the
Classic & Historic Automobile Club of Australia

ACN 004 677 570

September 2010
Volume 45 Number 5



Ken & Margaret Robinson's 1962 "S" Series Valiant with
Graeme Moore's 1958 Ford Zephyr Mk2 Convertible.
Parked at Williamstown at the Lunch stop.
Full details of the run inside.

Upcoming Club Events



Last of the Chrome Bumpers at Cora Lyn Sunday 3rd October
Tri-Club Picnic at Werribee Sunday 10th October
All Makes Swap Meet at Nagambie Sunday 17th October
Annual Luncheon at Moorabbin Airport Sunday 24th October
Presentation Day at Norton Park Sunday 28th November
See inside for details of all the above runs



To bring together persons with a common interest, to encourage the use, maintenance and preservation of automobiles built from the 1st January, 1931 up to 25 years old, without prejudice to make, model, method of manufacture or country of origin.

Committee

Secretary

Peter Galley & Janet Galley (O.A.M.)
PO Box 193 Kerrimuir Vic 3129
Ph 03 9890 8364

President

David & Margaret Landells
63 Billanook Way, Chirnside Park 3116
Ph: 03 9726 4884

Vice President

James & Colleen Allan
48 Danielle Crescent, Heathmont 3135
Ph: 03 9729 5097

Treasurer

Mick Whiting & Tina Brown
170 Dendy Street, East Brighton 3187
Ph: 03 9592 8713

Membership Secretary

Max Austin
82 Price Avenue, Mt. Waverley 3149
Ph/fax: 03 9802 6824

Editor

editor@chaca.com.au
Eddie Reynolds 03 9770 1231
eddienoelle@bigpond.com

Publicity Officer

James & Colleen Allan
48 Danielle Crescent, Heathmont Vic. 3135
Ph: 9729 5097

Technical Officer

Neville Kunnel
1 Val Court, Dandenong Vic. 3175
Ph. 03 8707 4101

Property Officer

Eddie Reynolds
36 Culcairn Drive, Frankston 3199
Ph: 03 9770 1231

Special Activities

Barry & Rosslyn Smith
33 William Street, Mount Waverley 3149
Ph: 9807 6813

Activities Officer

Vacant

Notice To All Reciprocating Clubs

Please address your magazines to
The Secretary
LPO Box 193
Kerrimuir Vic 3129

Meetings

1st Friday of the month (except Good Friday & January) at Deepdene Park Hall, Whitehorse Road, Deepdene. Tea, coffee and snacks are served at the conclusion of each meeting. Visitors and prospective new Members are welcomed.

Club Newsletter

The Journal is published monthly. Items for inclusion in the Journal must be mailed, emailed or passed on to the Editor at Club Meetings. The Committee reserves the right to edit or decline any article deemed unsuitable. Photographs submitted for possible publication should preferably be glossy 5"x 7" or 6" x 4" prints or high resolution jpg/bmp images to ensure best reproduction in the Journal. Opinions expressed in this publication are not necessarily those of the Club.

Journal Closing Dates

Nominally 2nd. Wednesday each month. Contact the Editor if worried.

Journal Nights

Nominally Thursday before the last Friday of each month

CHACA Life Members

Max Austin, Ray Griffin, Margaret Griffin,
Barry Smith, Jim Kerr, Dale Allen, Bill Kerr, John Hunt,
Tom Lambert, Roy Pepprell, Eddie Reynolds, Bob Mantle,
Patricia Wightman, Peter Galley, John Schuurman.
Deceased: Fred McGearry, Norm Watt, Don Main, Ian Davey
Eddy Dobbs Snr, Col Patience, Gordon Wightman.

Website

The Club's website www.chaca.com.au is updated regularly and features Club History, Club Promotions, an Events Calendar, a full Journal for downloading and many photographs of Club Events.

Archivist and Historian -

Margaret Griffin - 5977 6649

Webmaster

Mary Anne Irvine & Gordon Talbot
webmaster@chaca.com.au
PO Box 2004 Bayswater 3153 PH: 9720 6239

Journal Layout Editor

Janelle Thomas
76 Monique Drive Langwarrin 3910 PH: 9776 5370
janellet@tpg.com.au

All Makes Swap Meet Director

Ian Hanks
4 Mussert Avenue Dingley Village 3172 PH:9551 3447
ijhanks@optusnet.com.au

Library Custodian

Eric & Pam Chaplin
105 Manestar Road, Upper Beaconsfield 3808
Ph/fax: 03 5944 3312

This Months Meeting
8.00 pm-3rd September 2010
Deepdene Park Hall
Whitehorse Road, Deepdene

Presidents Report

At last months meeting a very interesting DVD about the Peking to Paris Rally was shown to the members, courtesy of Ralph Provan. Thanks Ralph it was very much appreciated. I hope that members will take the time to fill in the survey of the Australian Historic Motoring Federation and return the survey to them A.S.A.P. They will collate the information from members of Car Clubs all over Australia to lobby politicians and show them just how much money is generated from the hobby motorists and directed to charities as well as the Tourist industries and the motor industries as a whole.

Please do your bit, we need all the help we can get and the AHMF is going to bat for all the Hobby motorists. Safe Classic Motoring, David Landells, President.

Editorial

In keeping with the excellent monthly runs CHACA members have been treated to, Barry and Roz Smith have arranged for our Annual Luncheon to be held at Moorabbin Airport on September 24th. See details pp 5 and 9.

Grateful thanks must go to all the organisers of our previous runs. Our current system of having members from various parts of Melbourne and suburbs arranging club runs in their respective areas is working very well.

The end result is we have had outings ranging from a Working Horse display in Gippsland through the Oasis Nursery near Toorradin, out to Avenel (Annual Tour) followed by a foray into Williamstown and then a Pub Lunch in Geelong. We can now look forward to the Tri-Club Picnic, 10th October, Last of the Chrome Bumpers at Cora Lyn, and of course the Annual Luncheon.

Not forgetting the All Makes Swap Meet at Nagambie and our highlight of the year the Presentation Day at Norton Park.

Now for the commercial:- the AGM is coming, we need members to volunteer their services in order that the Club may continue in a similar vein for the next twelve months, please! You know the rest..... Activities officer, Special Activities, Editor, President, Vice President....., the list goes on.

Perhaps with the new (non executive) committee it may be decided to conduct committee meetings at members homes thereby creating a pleasant social atmosphere along the lines of our Journal nights, which is an occasion we all look forward to.

PS. What about an assistant Editor? With a view to taking over later would be a good idea if you would prefer to ease into the position more gradually.

Looking forward to having to beat you all back with a stick at the AGM,

Note that there are also committee positions that are not tied to any specific function. These are very important too. Eddie Reynolds.

Gentlemen please bring a plate of food for the general meetings.



Club Permit Scheme

FOR Special Use Vouchers:

Neville Kunnel (03) 8707 4101; Max Austin 03 9802 6824; Vin Forbes 03 9363 5228

FOR RENEWAL of your Vic Roads Permit:

Send to Neville Kunnel with a self-addressed stamped envelope. Neville will return it to you for you to pay at your nearest Vic Roads Office. You can also see Neville at meetings and on runs.

FOR New Applications: Contact Neville Kunnel

1 Val Court, Dandenong, Vic, 3175 Ph: 03 8707-4101

From the Secretary's Key Board

Elsewhere in this Month's Journal you will find a nomination form for committee positions.

The Club requires at least Five persons to commit some of their time, so that the Club can move forward, not into that abyss that we heard so much about during mid August, but, continue with the activities and programmes that we have enjoyed over the past Forty years.

The job of Secretary has been lightened with the help of Janelle who is taking the minutes at the general meetings, the job of Activities person has also been lightened and is shared around with members, so that's a start.

I look forward to your nominations coming through the mail, and if you are wanting to know what is involved in the committee positions, give me a bell, and I will send you a brief.

Peter Galley, Secretary.

August 2010 Raffle

The August Raffle raised a total of \$34.80.

1st. Prize went to Ralph Provan

2nd. Prize went to John Baker.

Congratulations!

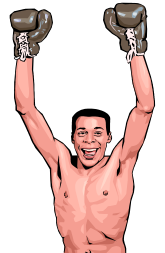

Register Supplement.

Steve Demanuele
15 Toorourrong Court
Whittlesea Vic 3757.

Les Huet de Froberville
19 Ingleton Court
Narre Warren Vic 3805.
1957 Cadillac Convertible.

Tim and Wanna wise
4 Launton Place
Cranbourne East Vic 3977
03 5995 4255
1980 Toyota Corolla E55 Sedan



TRI-CLUB PICNIC DAY

Sunday 10 October 2010

Visit to the B24 Liberator Restoration,
Corner Princes Highway & Farm Road, Werribee



The TRI-Club Picnic is an annual event which provides the opportunity for Veteran, Vintage and Classic car enthusiasts to spend a very pleasant day together.

This year's event will be organised by the Veteran Car Club of Australia (Vic) and the visit to the B24 Liberator restoration project promises to be a very interesting experience for all participants.

The devoted group at B24 Liberator Australia are well advanced with their restoration of the only remaining Liberator in the Southern Hemisphere using components which have been sourced from many parts of the world.

This aircraft is of great historical significance as B24 Liberators long range bombers served in the South West Pacific area during World War 11.

Our hosts from B24 Liberator Australia will provide conducted tours in groups of 10 people to ensure that we all get the chance to have a close inspection.

Starting from the RSL in Mary Street Spotswood (close to the Westgate Freeway (Melways Ref 41 J12) at 10:30am, we will travel directly to the B24 Restoration Hangar which is located on the corner of Princes Highway and Farm Road, Werribee (Melways Ref 205 F10).

\$5:00 per person admittance charge, tea and coffee \$3:00

Please bring your own food etc for lunch.

This is a Red Plate event which should attract a most impressive turn-out of Veteran, Vintage and Classic vehicles.

Enquiries: David Wright, Ph 03 9887 9401



Events & Swap Meets of Interest to Club members

October 1-4	CARNIVAL, CAMS NATIONAL MOTORING FESTIVAL Echuca—Moama
October 2-3	The Gippsland Vehicle Collection presents the 3rd Annual Melbourne to Maffra Rally Entry form www.gippslandvehiclecollection.org.au Ph: 5147 2118
October 3rd	Euroa Show and Shine, Phone: 03 5795 1347
October 17th	The Inaugural All Ford Display Day and cruise to Nagambie Lakes Regatta Centre Contact 03 9890 0524
October 29 to November 2nd	7th Gateway to Gippsland Rally, Hosted by the West Gippsland Vehicle Restores Club Inc. Open to all Classic, Veteran and Vintage Cars, Bikes and Trucks, Brian Connelly 0428 528 291
October 31st	Cars of the World, Show and Shine, Rochford Wines Coldstream, Yarra Valley Contact Charles Rogers MOB 04207 246 533 A/H preferable
November 28th.	C.H.A.C.A. Presentation Day. Norton Park.



Celebrate Together
Wattle Day
 Family Fun Day



Sunday 12 September 11am –3pm
 Wattle Park
 1012 Riversdale Road, Surrey Hills,
 Mel Ref: 60 J2



Healthy Parks
 Healthy People

Arrive about 10.30am

Enter off Riversdale Road and follow up to the Chalet, the entrance to “Our” allocated parking area is on the Eastern side of the Chalet.

Please note that I said “Our” parking area because we have ringside parking to the days activities. Activities include Tramways Big Band, crafts, performances, stalls, plant give -aways, Gourmet Farmers Market stalls, Ranger Roo, Melbourne Fire Brigade, face painting and much more.

There is plenty of parking space for us so please make an effort to attend and even bring along your kids, grandkids and enjoy a picnic lunch with other car club enthusiasts. Please note if you have to leave early do so at the rear of display cars, **DO NOT INTRUDE INTO PUBLIC AREA WITH YOUR CAR.**

(The management have asked that we stay until 3.15pm.)

So please come along and show off your cars.
 Enquiries Ian Hanks 9551 3447

C.H.A.C.A. ANNUAL LUNCHEON

DATE: SUNDAY 24TH OCTOBER 2010

TIME: 12.30 P.M.

VENUE: THE ROYAL VICTORIAN AERO CLUB
 FIRST AVENUE MORRABBIN AIRPORT
 MENTONE AEROBAR & BISTRO

ENCLOSED IS A MENU FOR YOU TO PICK FROM. DRINKS AT BAR PRICES.
 IF YOU ARE GOING TO ATTEND YOU **MUST RING** BARRY SMITH
 ON PH: 9807 6813 MOB:0408 440 240
LAST DAY TO BOOK OCTOBER 10TH
 See menu on page 9

BARRY SMITH
 SPECIAL ACTIVITIES OFFICER



MINUTES OF GENERAL MEETING OF CLASSIC AND HISTORIC AUTOMOBILE CLUB OF AUSTRALIA

**Held at Deepdene Park Hall, Whitehorse Rd, Deepdene,
on Friday 6th August 2010**

Chair: David Landells, President

Meeting opened at 8.10 pm.

Present: Approximately 24 members and visitors. Chair welcomed members, visitors and asked if there were any new members, and requested that all present sign the attendance book.

Apologies: Max Austin and Greg Chiefalo.

Minutes: Minutes of the previous meeting held July 2nd 2010. Minutes were signed as a true record. Moved—Tibbie. Seconded—Dennis Healy and carried.

Business arising from the minutes: None.

Reports

President—David Landells. “Did everybody get the AHMF Survey in last months Journal? I hope you filled it in and sent it off, our voices need to be heard by the politicians. We do not want older cars off the road, we contribute to the economy, tourism and charities. I received a communication from Motor Classica about their upcoming display of veteran and vintage cars in October at the Royal Exhibition Building. The Herald Sun is a major sponsor and Sterling Moss will be a guest judge. Augusts Journal Editorial talks about options for the new committee and any new ideas to get new people interested, AGM is coming up in November.”

Secretary—Peter Galley.

Correspondence in: Magazines and Newsletters from various Exchange Clubs, Federation Golden Oldies Tour for Vintage Vehicles 10-17 April 2011, Annual conference in Perth—agenda Old cars

Correspondence out: Letter to Kevin Churchill, Get Well card to Albert Blashki, OAM, HCVC.

Treasurer—Mick Whiting.

Statement of Accounts

Opening Balance:	\$8,712.82
Income:	NIL
Expenditure:	\$2,604.31
Closing Balance:	\$6,108.51

Vice President—James Allan. Promotions cheques coming in mail \$3,465.

Membership Secretary—Max Austin. Absent. 1 new member Tim and Wanna Wise, 4 Launton Place, Cranbourne East 3977. 1980 Toyota Corolla E55 Sedan.

Activities—David Landells. Vin Forbes: Williamstown run saw about 20 odd cars and 42 attendees visit the St John museum. Was very interesting to see what was there and learn of it’s history. We also visited the Marina and went to the Pirates Tavern for lunch. A bonus on the trip was a look at the old morgue which has been relocated four times, always near the waters edge as remains were thrown to the seagulls or washed away with the tide. Bob: Port Melbourne Authority is to sign long term lease on Museum saving it from being closed down. 22nd August was the All Makes Swap Meet at Croydon, 29th August was the Federation Picnic at Marong.

Special Activities Officer—Barry Smith. No report, thanks though to Eddie and Janelle for a great journal for August.

John Baker: The run to Geelong for lunch will take us on a 1 and a 1/2 hour journey through the country side and along the fault line. We will meet at the Mobil Servo at 10am and drive in line with the highway up towards Ballan. Vehicles with a bit of horsepower are needed for this drive. We then head down to Geelong for lunch at the Gateway Hotel where Senior Cards are accepted. Information on the fault line will be given out on the day.

Technical Officer—Neville Kunnel. One new registration.

Editor—Eddie Reynolds. Thanks to Ralph for article. I will be away in September, send any articles to Janelle, her address is on page 2 of the journal. I have name badges to hand out.

Property Officer—Eddie Reynolds. As above.

Special Reports—

AOMC: Graham Hutchinson. There hasn’t yet been a meeting, there will be one at the end of the month. The opening of the Chevy Day was very successful, the speakers were very well received.

The Federation of Motoring: Kevin Churchill. Kevin is away.

All Makes Swap Meet: Ian Hanks. Ian is away. Next swap meet is on the 22nd August, some help on the day will be needed.

Special Effort—\$34.80 was raised tonight. 1st prize went to Ralph Provan. 2nd prize went to John Baker.

Cars, parts for Sale and Wanted—Tibbie has for free an early Holden wheel and tyre, 95% tread. Feel free to take it if Tibbie is not home, it is leaning against the fence near an F100 truck.

Reports from members of recent motoring events— Nil

General Business— Bill Wellwood passed away on the 5th July. He was a humble man and friend to anyone interested in Hobby cars. His charity work was numerous and it was amazing to behold him in action at the Shannons Auctions, a real showman. He always had time for everybody and will be greatly missed. Help is not needed for the BBQ at Shannons Auction on the 16th August. Max Austin: Renewal for Journal subscriptions will be in the September and October journals you have till the end of November to get them in. Nomination forms for the committee will be in September journal, we are grateful for all help. Bob Clarke: Wrote to Nicola Obson local Fed Member about the Cash for Clunkers scheme and outlined the benefits of the old car movement and how they are not a burden. The USA scrapped their scheme as it cost more than was saved. “I then received a letter asking me to vote for Labour with no reference to my earlier letter, I am not giving up and I am not voting for Labour”. John: Dr David Warren passed away at age 85. He was an electronics expert and worked on the problems of jet fuel tanks blowing up as they expanded and shrank. He came up with the idea of a black box flight recorder but the concept was rejected in Australia until 1962 when they became mandatory. Dr. Warren invented many things in his time and he was also a member of the Morris Minor Club.

Meeting Closed at 9.03pm.

Next Meeting Friday 3rd September at the Deepdene Park Hall 8pm

To tantalise your taste buds this is the menu for the Annual Luncheon, September the 24th, at Moorabbin Airport, see page 5.

LUNCH MENU ONLY	
Open grilled chicken sandwich- Topped with grilled pineapple, bacon, cheese and tangy mango sauce, served with chips	18.00
Open char-grilled steak sandwich- Topped with caramelised onion, bacon, cheese and garlic mustard mayonnaise, served with chips	19.00
Open smoked salmon sandwich- Topped with spinach, tomato capers, cream cheese and onion, served with chips	18.00
Ham, cheese & tomato foccacia- Fresh ham, tomato and tasty cheese lightly toasted	9.50
Vegetarian foccacia- Char-grilled eggplant, pumpkin, spinach, sundried tomatoes, cheese and pesto	9.50
Cajun Chicken Focaccia - Char grilled Cajun spiced chicken, with lettuce, mayonnaise & Spanish onion	10.00
SALADS (LUNCH OR DINNER)	
Prawn, Salmon and Avocado- Garden salad with smoked salmon, prawns, avocado, Spanish onion, capers and cocktail sauce	24.00
Mediterranean Lamb- Garden salad with grilled lamb filets, olives, feta topped with garlic yoghurt dressing	28.00
Cajun Chicken- Garden salad with lightly spiced Cajun chicken filets and roasted potatoes, topped with sour cream	20.00
Classic Caesar- Cos lettuce, bacon, parmesan cheese, anchovies, croutons, tossed in a light creamy dressing and topped with a poached egg	20.00
Chicken Caesar- Classic Caesar salad topped with grilled chicken	23.00
Salmon Caesar- Classic Caesar salad topped with fresh smoked-salmon	23.00
PASTA (LUNCH OR DINNER)	
Carbonara- Bacon, cheese, spring onion and egg finished in a light cream sauce	17.00
Chicken Satay- Chicken, mushrooms and spring onion finished in a creamy peanut sauce	18.00
Vegetarian- Roast pumpkin, mushrooms and spinach finished in a creamy tomato sauce	17.00
Aero Special- Salami, sundried tomatoes and olives in a light tangy sauce	17.00
Marinara- Fresh prawns, scallops, fish, calamari and mussels finished in either olive oil and garlic or tomato base	25.00



STARTERS	
Bowl of Chips	6.00
Garlic Bread	3.00
Trio of Dips- served with warm pita bread and a side salad	15.00
Pan-fried garlic prawns- served on steamed rice, finished in a creamy garlic and white wine sauce	16.00
Lightly battered prawns- Served with sweet chilli sauce and a side salad	16.00
Salt and Pepper Calamari- Served with sweet chilli sauce and a side salad	15.00
Home-made spring rolls (6)- Served with sweet chilli sauce and a side salad	10.00
MAINS	
Fish & Chips- Served with homemade Tartare sauce	20.00
Jumbo Burger- Bacon, egg, onion, lettuce, tomato and cheese	18.00
Chicken Tropical Burger- Pineapple, bacon, cheese and BBQ sauce melted cheese	18.00
Garlic Char-grilled Chicken Breast- Topped with a light and creamy garlic sauce	23.00
Veal Scaloppini- Served with a red wine jus on steamed rice	26.00
Martinated Lamb Fillets- Served with a classic sauce and served on steamed rice	26.00
Pan-fried Prawn and Scallop Combo- In a creamy garlic-brandy sauce and served with sweet chilli sauce	23.00
Salt and Pepper Calamari- Served with a light and creamy sauce	21.00
Fried fish and chips- served with homemade Tartare sauce	10.00
Cheeseburger served with chips	10.00
Carbonara Pasta- Bacon, cheese, spring onion and egg finished in a light cream sauce	10.00

**All meals served with chips and your choice of salad or vegetables-*
**For Soup of the day, fish, fish, steaks and desserts, please refer to the Specials Page*



Would this help?



SUGESTION

GNIHCAYMO

HOU R

INITIA.

ISOCKET

m ce
m ce
m ce

12"
WET

JUMPING END
END

dea

EXIT LUNCH
LUNCH

iiiiiiiiii

●
—
●

HAPPY
WORLD

LEADTEN

FILE

INSUFFICIENT

MARKET

JJJ BBB

TOTOO

≡

aminpm

LOOK

1
PARLIAMENT

FRUC BIBLE

WETHER

CONCRETE

2345
67890

EMPLOY T
MEN

CANCELLED
SHOW

LAW ON

RUM LIES OUR

WATER

Answers next month

Santa Fe Trailways bus



Built out of plywood during WW II in Santa Fe's Wichita, KS., shops to conserve valuable war materiel, the Victory Liner was used to transport civilian employees to military arms factories during the war. It had a passenger capacity of 117.

This shot only adds to the confusion about the mechanicals of the bus. Did the driver sit in the center and swing with the tractor unit, or did the Santa Fe folks figure out some sort of hydraulic steering setup that allowed the driver to sit atop the cab? We can guess that a plywood-bodied vehicle has a very limited lifespan.

**117
WAR WORKERS
FOR THE ASSEMBLY LINE
EVERY
TRIP**

SANTA FE TRAILWAYS

★ Near a Mid-Western city recently, a huge new war plant swung into production. The "shift-by-shift" transportation of war workers to and from this plant is being speeded by Santa Fe Trailways' new "VICTORY LINER"—a 117 passenger bus conceived, designed and built entirely by Santa Fe engineers and skilled workmen. The "VICTORY LINER" is saving tires and gas for hundreds of war workers every day! This is only one of countless contributions to the war effort made by the bus industry. If your trip should be delayed, or your bus crowded, please be cooperative . . . essential travel must come first!

BUS DEPOT 722 Jackson St. Telephone 115

Santa Fe TRAILWAYS

BUY UNITED STATES WAR BONDS AND STAMPS

Warbon, National Trailways War Service

According to one contemporary newspaper account, the Victory Liner was the largest bus in the world and could be directly attributed to Gene Allen, the general manager of Santa Fe Trailways at the time. Allen also had a hand in converting a couple of two-story sleeper buses into transport buses for the war effort, expanding their capacities from 40 to 54. Where exactly they travelled was left rather vague in a series of ads that ran in newspapers across the Midwest such as the one on the left, taken from the December 31, 1942, issue of the Chillicothe (Missouri) Constitution-Tribune.



Thanks to John Baker for this article.

Thanks to Peter Hibbert for sending in these photo's of his latest restoration project. A 1947 (two door) Tudor.



CHACA Monthly Run Williamstown 18th. July 2010

What a great day, and a day with a difference! We assembled at the service station on the Melbourne side of Westgate Bridge. Some stayed in their cars waiting for the signal to head off to Williamstown. The weather was quite cool with a biting wind. It was a busy spot with two other car clubs using the same area to congregate before driving off to their individual destinations.

After a short briefing from Vin we duly set off for the St. John's Museum. There we were treated to a comprehensive overview of the museum and St. John's Ambulance service in general. Vin presented the speaker with one of our 30 year books as a token of appreciation.

We've come a long way since those early days in communications techniques, first aid procedures and transport.

That was made even more evident when we viewed the conditions they had to work in, particularly during the wars, starting with the Boer War and

continuing up to the present time.

Their displays of model cars featuring ambulances of all shapes, sizes and a variety of manufacturers was impressive.

Next, we headed off to our appointed lunch stop in the Pirate's Tavern which is located in the old Warehouse and Bond store area on Nelson Place.

Then after lunch we were given a "tour" (the building was about 15 foot square) of the old Williamstown Morgue. Fortunately it wasn't being used as such at the time.

While we were having lunch the weather finally broke and it started to rain. Didn't matter now, we were under cover and very warm, but it meant a wet drive home.

It was a good day and we are now looking forward to the next run which is being organised by John and Louise Baker on 15/8/10. to Geelong.

See you there!
Eddie Reynolds.

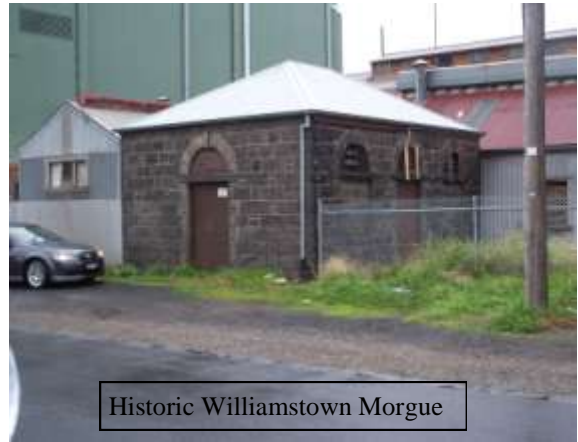

Historic Williamstown Morgue

Those who attended.

Vin & Lana Forbes	'55 Dodge	Graeme Moore	'58 Zephyr
Rod Bundy	'54 Daimler	Ray & Margaret Griffin	'37 Chev Ute
Bob & Judy Wilson	'80 Oldsmobile	Alan & Margaret Lethborg	'46 Buick
Doug Gorham	'47 Plymouth	Max & Barbara Austin	Modern
Russell & Lesley Betts	'55 FJ Holden	Barry & Roz Smith	Modern
Neville Kunnel	'65 Mustang	Kevin & Erica Churchill	Modern
Lester & Yvette Cole	'34 Plymouth	Ron & Loretta McNamara	Modern
Eddie Reynolds & Graeme Tibbett		'53 Willys Overland Ambulance	
Charlie & Ghofar Stone		Passengers with Lester & Yvette	
Kathy Austin		Passenger with Lester & Yvette	
Graham & Nancy Hutchinson		'34 Hupmobile	
Ken & Margaret Robinson		'62 Valiant "S" Series	
Bob Clark		'55 Studebaker Commander	
Mick & Tina Whiting		'75 Mercedes Benz Conv.	
Jeff & Margaret Albon		'79 Fairlane 500	





A Brief History of St. John Services.

The Hospital of St John was built in Jerusalem in 1080AD, to care for the sick and injured pilgrims.

The Order of the Hospital of St John of Jerusalem (The Hospitallers) was created by Pope Paschal II in 1113AD. The Templars were formed in 1120AD.

The Hospitallers were supported by eight ethnic groups, called "Tongues", one in England from 1140AD

PROVINCE	FRANCE
AUSTRIAN	GERMANY
ENGLAND	ARAGON
CASTILE	ITALY

The Order was expelled from the Holy Land in 1291AD

- to Rhodes 1309-1522AD
- to Malta 1530-1798AD
- to Russia 1798-1801AD
- to Rome 1834- present as "The Sovereign Military and Hospitaller Order of St John of Jerusalem"

The Commandery in England became a Grand Priory in 1185AD, with St John's Gate, Clerkenwell, as its Headquarters.

The Order in England was

- suppressed by King Henry VIII in 1540AD.
- restored by Queen Mary I in 1557AD.
- suppressed by Queen Elizabeth I in 1559AD.
- restored by Queen Victoria in 1868AD as "The Most Venerable Order of the Hospital of St John of Jerusalem".

The Order of St John in Australia began as an Overseas Branch of the Grand Priory in the British Realm of the Hospital of St John of Jerusalem.

In 1941 Australia became a Commandery, except for Western Australia which remained a District attached to England.

In 1946 Australia became a Priory, with a Commandery in Western Australia answerable to the Australian Priory.

The Governor-General is the Prior, with State Governors as Deputy Priors. The Queen is Sovereign Head of the Order.

The Priory Headquarters is in Canberra Avenue, ACT.

In Australia, St John Ambulance Association taught First Aid from 1883.

The first Division of the St John Ambulance Brigade in Australia was formed in NSW at Glebe in 1903.

Victoria followed in 1910.

St John volunteers provided major assistance to the British Army Medical Services during the South African "Boer War" Campaign of 1899-1902.

In all, 2046 St John members (out of a total Brigade membership of 8233) provided about one quarter of the total medical personnel serving the Army of 250,000 soldiers.

During the war ten members were mentioned in dispatches as having rendered meritorious service and two were awarded the Medal for Distinguished Conduct.

61 members died during the war, mainly from enteric fever.

A specific medal was awarded to St John members in addition to the medal of the South African Campaign.

BEGINNINGS OF ST JOHN IN VICTORIA

Dr James Edward Neild called a Public Meeting in 1883. It formed a Branch in Victoria of the St John Ambulance Association.

The Association, begun in England in 1877, provided the local Branch with textbooks, authorized Certificates and awards for the next 70 years until the formation of the Priory of St John in Australia in 1947.

In 1908 the First Aid Volunteer's Association (FAVA) (see photo at left) was formed to give public First Aid to crowds at the visit of the American Fleet. Members were all St John certificate holders.

The first FAVA President was Dr George Horne (see photo below). In 1910 he became the first Commissioner in Victoria of the St John Ambulance Brigade.

The Brigade began with the Melbourne Metropolitan Division and the Brighton Nursing Division (see photo at right).

FAVA dwindled as the Brigade grew stronger. It disbanded in 1919.

SUPERSTOP BRAKE & CLUTCH®

Superstop Brake & Clutch P/L

ABN: 83 112 916 168

727-729 Whitehorse Rd, Mont Albert 3127.

T: +61 3 9890 1924 | F: +61 3 9890 5502

E: sales@superstop.com.au

W: www.superstop.com.au

SUPERSTOP SPECIALISES IN:



- **DISC PADS & ROTORS**
- **CLUTCH KITS**
- **BONDED SHOES**
- **HYDRAULIC PARTS**
- **DISC, DRUM & FLYWHEEL MACHINING**
- **CYLINDER HONING & RECONDITIONING**
- **BRAKE HOSE MANUFACTURING**



PREMIUM SERVICE – 4 DELIVERY DRIVERS

WE LOOK FORWARD TO HEARING FROM YOU SOON !

BILL ELDRIDGE MECHANICAL REPAIRS

Club Member

VINTAGE & CLASSIC ALL MAKES -ALL MODELS

- All mechanical work
- Engine reconditioning
- Panel work & Repairs
- Full Restorations
- Water Pumps modified
- Clutch & Brakes



"When better cars are (re)built, Bill will (re)build them"

Factory 20, 166 Bridge Road, Keysborough Vic. 3173

Telephone: (03) 9798 8636

A.H. (03) 9798 1995

COLJEN GEAR CUTTING & MACHINING

- | | |
|------------------|-------------------|
| Spurs | TB Pulleys |
| Helicals | Slotting |
| Splines | Milling |
| Sprockets | Turning |

Colin Woods & Jenny Stacker

Tel: (03) 9458 2741

Mobile: 0425 815 849

Fax: (03) 9458 2741

Email: gears@coljen.com

**6 Beatrice Avenue, West Heidelberg
Victoria 3081**

**We always hear 'the rules' from the female side.
Now here are the Rules from the male side. These are our rules:-**



Please note.... these are all numbered '1' ON PURPOSE!

1. Breasts are for looking at and that is why we do it. Don't try to change that.
1. Learn to work the toilet seat. You're a big girl. If its up, put it down. We need it up, you need it down. You don't hear us complaining about you leaving it down.
1. Saturday = Sports. Its like the full moon or the changing of the tides. Let it be.
1. Shopping is NOT a sport. and no, we are never going to think of it that way.
1. Crying is blackmail.
1. Ask for what you want. Let us be clear on this one: Subtle hints do not work! Strong hints do not work! Obvious hints do not work! Just say it!
1. Yes and No are perfectly acceptable answers to almost every question.
1. Come to us with a problem only if you want help solving it. That's what we do. Sympathy is what your girlfriends are for.
1. A headache that lasts for 17 months is a problem. See a doctor.
1. Anything we said 6 months ago is inadmissible in an argument. In fact, all comments become null and void after 7 days.
1. If you think you are fat, you probably are. Don't ask us.
1. If something we said can be interpreted two ways, and one of the ways makes you sad or angry, we meant the other one.
1. You can either ask us to do something or tell us how you want it done. Not both. If you already know best how to do it, just do it yourself.
1. Whenever possible, please say whatever you have to say during commercials.
1. Christopher Columbus did not need directions and neither do we.
1. ALL men see in only 16 colours, like Windows default settings. Peach, for example, is a fruit, not a colour. Pumpkin is also a fruit. We have no idea what Mauve is.
1. If it itches, it will be scratched. We do that.
1. If we ask what is wrong and you say 'nothing', we will act like nothings wrong. We know you are lying, but it is just not worth the hassle.
1. If you ask a question you don't want an answer to, expect an answer you don't want to hear.
1. When we have to go somewhere, absolutely anything you wear is fine. Really.
1. Don't ask us what we are thinking about unless you are prepared to discuss such topics as Sex, Sport, or Cars.
1. You have enough clothes.
1. You have too many shoes.
1. I am in shape. Round is a shape.
1. Thank you for reading this; Yes, I know, I have to sleep on the couch tonight, but did you know men really don't mind that, its like camping.

Thank you to Gail Evans for this *set of rules!*

Club Website:
www.chaca.com.au
8,500 Hits

Club Regalia

SAMPLE

Name Badges - \$10.00

CHACA
Windscreen Stickers
\$2.00 each

For all your Club Regalia needs, please
contact Eddie Reynolds on 9770 1231

**THE 60'S AMERICAN MUSCLE CAR CLUB
PROUDLY PRESENTS :**



2010

The Manhattan
Chr Heatherdale & Canterbury Rd, Ringwood (Melway 63 D1)

Sunday November 21st
BACK AGAIN IN 2010

ALL AMERICAN 2 & 4 DOOR CARS & BODS WELCOME

CARS OPEN: 8am	DISPLAY CARS	\$5 DONATION DISPLAY CAR
10am GENERAL PUBLIC		\$5 DONATION GENERAL PUBLIC
		(KIDS UNDER 16 FREE)



Event tickets \$10.00. 03 9822 1694. www.60smcc.com.au



American Breed 2010
is brought to you by:









Club permit vehicles welcome. Please note: Consumption of alcohol in the car park is not permitted.

Taken from an article by Greg Smith, Regional Director International Road Assessment Program (iRAP) in *Motoring Directions*, The Australian Automotive Association newsletter, January 2010.

There is no doubt that safer roads are needed. Most crashes are caused by human error so road safety initiatives have traditionally focused on the driver

In order to prevent crashes.

More recently engineers have focused on mediating the outcome of a crash by designing safer vehicles and roads.

The AusRAP (Australian Road Assessment Program) Star Ratings are based on a detailed visual inspection of a road's design elements. The data is collected using specially equipped vehicles that record digital photographs (images) of a road (generally at 5m to 10m intervals) using an array of cameras aligned to pick up various views of the road (forward, rear, side - left and right). The vehicles are able to drive along the road at almost normal speed while collecting the information.

The images are "streamed" to form a "video" of the road network.

Analysts can either take a virtual drive or check frame by frame to make accurate measurements of elements like lane widths, shoulder widths and the distance between the road edge and fixed hazards (trees, poles etc).

To date more than 30 000 km of state and national highways have been assessed by AusRAP A Road Protection Score is calculated for each section of road and, in association with research made by ARRB, Austroads and European sources, a Star Rating is made.

In Victoria RACV (as a member of AAA) has used AusRAP Star ratings to show the life-saving impact safer roads can have.

Star Ratings for the Calder Highway before and after upgrades improved from two stars to four stars.

The upgrades involved duplication of single carriageway, which had the effect of dramatically reducing the risk of head on crashes, and improving roadsides, which strongly influence the risk of injury in a run-off road crash.

AusRAP research shows that this type of improvement can have a dramatic effect on crash costs. Correlating actual crash data with Star ratings it was found, on average, that improving a road's Star Rating from two to three stars halves crash costs. Similarly, improving from three to

four stars halves crash costs again.

As an affiliate of iRAP AusRAP has produced a Road Safety Toolkit which is available on the internet.

As new technology becomes available iRAP will continue to evolve.

The program is presently undertaking a pilot project in Queensland in partnership with the State road authority to extend its approach to specifically cater for motorcyclists, pedestrians and cyclists in rural and urban settings.

For more information on AusRAP, visit www.ausrap.org.

For more information on iRAP visit www.irap.org.

Dennis Brooks HCVC



What do you see?
A woman's face or
a man playing a
saxophone?

AUTOMOTIVE SURPLUS PTY LTD
Incorporating Vanguard Co (formerly of Elizabeth St, Melbourne)

New Old Stock
Parts For
Most Makes
Cars, Trucks, Tractors

MECHANICAL, ELECTRICAL, SUSPENSION, STEERING,
CLUTCH, BRAKES AND RECONDITIONED WATER PUMPS
HILLMAN, HUMBER, SUNBEAM, COMMER, GM-H,
FORD (SV & OHV), CHRYSLER, AUSTIN, MORRIS, WOLSELEY,
RILEY, MG, STANDARD, TRIUMPH, JAGUAR, DAIMLER

Veteran - Vintage - Classic - Modern

☆ *Australia's largest stock of pistons, rings, bearings,
valves, etc* ☆ *Gaskets made to order*
☆ *Surplus stock bought*

"One Call Does It All"

34 Thornton Crescent Mitcham Vic 3132
Ph 03 9873 3566 Fax 03 9874 1485 Mail Orders Welcome
Mon-Fri 8.30am to 5.00pm, Sat 8.30am to 12 noon
Email: automotivesurplus@bigpond.com
Website: www.autosurplus.com.au

Classic and Historic Automobile Club of Australia *Display and Presentation day*

28th. November 2010

11.30 to 2.00.....Novelty Events for everyone.

2.30.....Father Christmas arrives.

3.00.....Presentations and Awards.

*All Voting Forms for
Favourite Vehicles to be
Lodged by 2.00pm.*

We have prizes for:-

- *Lucky Entry Number*
- *How many lollies in jar*
- *Novelty Events*

Christmas Hamper
Get in early!

Buy your raffle tickets for the giant hamper today.

Raffle drawn at the next General meeting
on 3rd. December 2010. "Ladies Night".

*"How Many Lollies in Jar Competition
Closes at 2.30pm.*

Have a Nice relaxing Day and
Join in the Activities.

Your Lucky Number is.....



PERFECTLY TIMED PHOTOS.COM

Perfectly Timed Photos.



PERFECTLY TIMED PHOTOS.COM

Buy, Swap and Sell

Advertisements in this column will appear for three consecutive months unless instructions to the contrary are received by the Editor. Victorian State laws require all advertisements for registered vehicles to display a Price and Registration Number, and for unregistered vehicles, the sale price together with the engine or VIN/Chassis number.

Advertisements that do not comply with the above will not be listed, nor will it be the Editors responsibility to seek such information.

SELL: Tyres all new: Pair 700 x 14 Dunlop 6 ply tubeless, One Commander 7.50 x 16 whitewall
 37—48 Ford Thermostats
 32—34 Ford Double pinion cup
 28—Rear wheel rollers, hub seals, axle seals
 65 Galaxie Radiator support panel
 105E Anglia Grille
 CD Cortina Grille
 29 Marquette rear end no drums
 Wal Marten, Home 03 5786 1667 Work 03 9467 1464 (0510)

WANTED:

1980's Single wheel "Big Boot" Trailer.
 Complete—or wheel assy—any condition, for disability scooter transport behind Classic Car.
 Due to a worsening of my spinal condition, I am now unable to lift my dismantled Electric Scooter in and out of the boot of my '55 Stude. This obviously precludes any further use of the Stude. Restricted neck relation also rules out use of a standard box trailer, not to mention lack of storage space. A "big boot" can be modified to carry the scooter assembled and light enough to tilt onto it's side for storage in my carport.
 Phone Bob Clark anytime 03 9391 8327 (0510)

SELL: 2 Die cast "T Ford Models" 1/25 Scale collectors replicas, new in original packaging, 1st is a 1918 Mobil Oil Tanker. 2nd is a 1912 Delivery Van. Both in mint condition. \$50 each or \$90 the pair. Telephone 8669 2069 (Melbourne area) 5611 0817 (Warrigal area) Mobile 0406 709 761, email me at tellatale@dcsi.net.au and I can send colour pictures. John Hughes. (0710).



SELL: Rambler Classic 1964. Needs lots of TLC. Rebuilt motor, receipts available. Stainless steel exhaust. Fair price wanted, make an offer. Receipt available C. Giovanelli (Murphy) Phone: 02 6795 3770 Mob: 0419 483 520 (0810)

WANTED:

1980's Single wheel "Big Boot" Trailer.
 Complete—or wheel assy—any condition, for disability scooter transport behind Classic Car.
 Due to a worsening of my spinal condition, I am now unable to lift my dismantled Electric Scooter in and out of the boot of my '55 Stude. This obviously precludes any further use of the Stude. Restricted neck relation also rules out use of a standard box trailer, not to mention lack of storage space. A "big boot" can be modified to carry the scooter assembled and light enough to tilt onto it's side for storage in my carport.
 Phone Bob Clark anytime 03 9391 8327 (0510)

1980's Single Wheel "big boot" Trailer.
 Complete — Or Wheel Assy — Any Cond.
 For Disability Scooter transport behind Classic Car.
 Ph. Bob Clark - Anytime 03 93918327

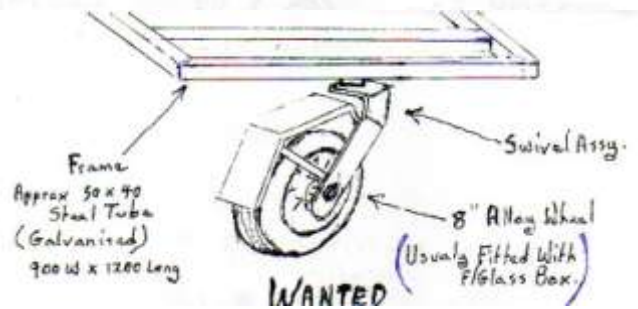



Can anyone throw any light on this plate?
 It recently came into the possession of the Club but we don't know the history of it or where it came from.
 If you can help please ring anyone on Committee.



The Perfect Password

A woman was helping her husband set up his computer, and at the appropriate point in the process, she told him that he would now need to enter a password. Something he could remember easily and will use each time he has to log on.

The husband was in a rather amorous mood and figured he would try for the shock effect to bring this to his wife's attention. So, when the computer asked him to enter his password, he made it plainly obvious to his wife that he was keying in....

P... E... N... I... S...

His wife fell off her chair laughing when the computer replied:

PASSWORD REJECTED. NOT LONG ENOUGH



A frustrated wife buys a pair of crutch-less knickers in an attempt to spice up her dead sex-life. She put them on, together with a short skirt and sits on the lounge opposite her husband. At strategic moments she uncrosses her legs ...enough times till her husband says..... "Are you wearing crutch-less knickers?" "Y-e-s", she answers with a seductive smile. "Thank God for that....I thought you were sitting on the cat." He never heard the gunshot!



Grandma and Grandpa were watching a religious healing program on TV..... The evangelist called to all who wanted to be healed, to put one hand on the TV and the other on the body part they wanted healed..... Grandma hobbled to the TV and put one hand on the TV and the other on her arthritic hip. Grandpa made his way to the set and put one hand on the TV and the other on his crotch. Grandma looked at him with disgust: "You just don't understand, you old coot, the purpose of this program is to heal the sick, not raise the dead."



ActonPrint

GROUP

Gary Galvin

TEL: (03) 9729 4500
FAX: (03) 9729 4544
MOB: 0411 606 670
EMAIL: acton@actonprint.com.au
WEB: www.actonprint.com.au

1/11 Michellan Crt.
Bayswater VIC. 3153

Mega Trim Motor Trimming

21 Cheltenham Rd Dandenong
Phone 9792 - 9952. Mobile 0438 746 626

Or drop in for a free Estimate

Complete Classic Car Upholstery Restoration Specialists
All work completed by Multi Award Winning Tradesmen with over 20 years experience

- ◆ Leather
- ◆ Cloth
- ◆ Vinyl
- ◆ Diamond buttoning
- ◆ Convertible Tops
- ◆ No job too big or small



TOMORROW'S BATTERY IS HERE TODAY!

OPTIMA CRANKING



THE ULTIMATE STARTER

- **FASTER, CRISPER STARTS!**
The OPTIMA 12-volt models deliver 850 Cold Cranking Amps at 0°F.

- **LONGER BATTERY LIFE!**

In performance tests the OPTIMA lasted three to five times longer than conventional, flat plate batteries.

- **UNEQUALLED VIBRATION RESISTANCE!**

Vibration is a primary killer of conventional batteries. OPTIMA's tightly wound SPIRALCELL resists jarring and vibration, and eliminates plate shedding.

- **UNSURPASSED SAFETY/ZERO MAINTENANCE!**

Acid can't leak, even if the battery is cracked open. Plus, no corrosion can form on cables, terminals or the vehicle. And you never add water.

- **MORE POWER IN ANY CLIMATE!**

Tests prove the OPTIMA performs better in extreme hot or cold temperatures than conventional lead-acid batteries of similar size.

- **FASTER RECHARGE!**

Greater plate surface area and lower internal resistance allows the OPTIMA to recharge in less time than conventional batteries.

- **EASY TO TRANSPORT!**

Because the OPTIMA is non-hazardous, it can be shipped by air.

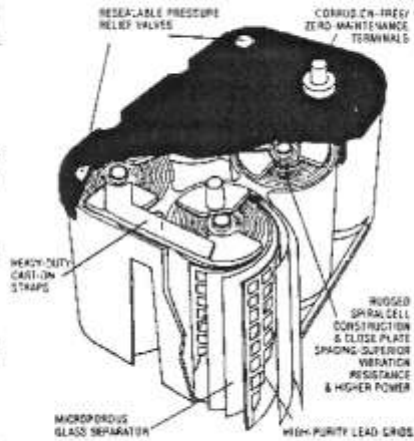

ONLY OPTIMA'S SPIRALCELL TECHNOLOGY OFFERS THESE BENEFITS



THE ULTIMATE STARTER Club Member

OPTIMA DEEP CYCLE

THE ULTIMATE POWER SOURCE



- **QUICK RECHARGE!**

The equipment/vehicle spends more time running, reducing down time and improving productivity.

- **FAST ENERGY RESPONSE!**

The OPTIMA delivers peak power faster. There is less capacity reduction with high current loads.

- **CLEAN POWER!**

Consistent, stable voltage throughout the discharge provides better power to your equipment.

- **BETTER CYCLING!**

The unique SPIRALCELL design and chemistry allows the OPTIMA to out-cycle most conventional deep cycle batteries. This means the OPTIMA lasts longer and is more economical for users.

- **COMPLETELY SEALED/ZERO MAINTENANCE!**

With absorbed electrolyte and sealed construction, the OPTIMA won't cause corrosion or leak, even if cracked open. OPTIMA is safer for people, equipment and the environment. And you never add water.

- **UNEQUALLED VIBRATION RESISTANCE!**

Unique SPIRALCELL design is virtually unaffected by vibration and jarring that shortens the life of conventional batteries.

OPTIMA BATTERIES (AUST) PTY LTD 111 MAROONDAH HIGHWAY LILLYDALE VIC 3140 Tel: (03) 9735 0039 Fax: (03) 9735 1842

www.chaca.com.au

Affiliated Clubs

*Independent Clubs Affiliated with the
Classic & Historic Automobile Club of Australia*

**Classic & Historic Automobile Club
of Australia Wagga Wagga Region Inc.**
Secretary: Steve Medlen, Phone 02 6931 2588
PO Box 749, Wagga Wagga, NSW 2650

Meetings:

*First Monday of the Month, at Clubrooms,
Wagga Wagga Showground's 7.30pm. Guests and visitors
are welcome.*

Morgan Country Car Club

Secretary: Michelle Grenness
PO Box 428, Albury, NSW 2640

Meetings: At Clubrooms on Jindera Sports Grounds,
First Friday of every month 7.30pm.
Some times on the first Sunday of the month.

Classic & Historic Automobile Club of Australia Sydney Inc.

Secretary: Charles Grimwood
PO Box 306 Wentworthville, NSW, 2145.

Phone 02 9635 5870 email: abfab@bigpond.net.au

Meetings: *All Sunday meetings start at 2pm. Members may
arrive from two hours prior to meeting times to have meal
and chat.*

Classic & Historic Automobile Club of Caboolture Inc.

Secretary: Kim Bowers
PO Box 514 Caboolture, Qld. 4510, . Phone 07 5495 4683
email: secretary@chacc.com

Meetings:

*2nd Sunday of the Month. Meeting at the Sundowner
Hotel car park, Caboolture at 6.30am*



**CRANKSHAFT
REBUILDERS**

YOUR COMPLETE ENGINE MACHINE SHOP

Trust your machine work to the business with
30 years experience & the most modern & technically
advanced engine reconditioning equipment.



By **CRANKSHAFT REBUILDERS**

Manufactured Crankshafts

Auscraunks are all wholly Australian made. We manufacture world class crankshafts for many of the top racing teams & engine builders throughout Australia. Our Crankshafts are often exported to New Zealand & Europe. Through state-of-the-art technology, advanced processes & practical engineering Auscraunks have become one of the leaders in crankshaft innovation & manufacturing. We pay particular attention to detail & manufacture crankshafts to suit customers individual needs & requirements.

• 4340 Non Twist Forgings

Manufactured for high performance for small block V8 Chevrolet, Holden, Ford, Rover & Chrysler. We are the only company in the world to offer a fully counter weighted forged crankshaft. Ultra light, rifle drilling, straight shot oiling system.

These crankshafts are used in the following applications:

- V8 Supercars
- Historic No/Nb & Bianke Muscle Cars
- Ski & Jet Boat Racing
- Pro Stock Drag Racing
- Street & Strip High Performance
- Oval Track Sprint Car Racing

• Billet

Using high quality steel & heat treating processes. Custom crankshafts for many applications.

Vintage & Historic Restoration. Performance Motorsport.

Some of the shafts manufactured in the past include :

Alfa P3, Bugatti Type 44, Singer Le Mans, Alvis, Ferrari, Porsche, Lamborghini, Jaguar, Bentley, Riley, Repco Brabham, Ford BDA, Austin Healey 4 & 6cyl, Ford Capri V6, Nissan L & RB series, Mini Cooper, Holden 202, Ford BA XR6 Turbo.



• Cast Iron

- MG TC Replacement
- Holden V8 Stroker 345-383ci
- Rover V8 Stroker 4.2-5.0lt
- Ford 302W Stroker 347

Performance Enhancements

- Performance modifications to factory cranks
- Knife edge & radius of counter weights
- Taper turning & lightening holes to reduce weight
- Oil hole teardrop/chamfering & oil feed improvements
- Doweling of rear flange to fly wheel

Engine Block

Cleaning
Crack Testing
Pressure Testing
Boring & Honing (Sunnen CK10 & SV10)
Cylinder Sleeving
Surface Grinding & Milling
Alloy Honing & Lapping.

O-Ring Installation
Line Boring & Honing (Sunnen)
Main Cap Conversions
Sonic Testing
Diesel Shoulder Boring
Bearing Remetalling

Crankshaft

Crack Testing
Heat Treatment
Stress Relieving

Journal Reclamation
Stroking
Precision Grinding

Con Rod

Shot Peening
Resizing (Sunnen)
Bolt Conversion

S.E. Bush Replacement
Piston Pin Fitting
Bearing Remetalling

Cylinder Heads

Crack Testing & Repair
Pressure Testing
Alloy Welding
Straightening
Serdri Valve Seating

Valve Seat Inserting
Valve Guide Replacement
K-liner Installation
Performance Modification

Balancing

Dynamic Engine Balancing
Flywheel/Clutch Assemblies
Rods & Pistons

Crankshaft Rebuilders Pty Ltd
Cranky Manufacturing Pty/Ltd T/A Auscraunks
www.crankshaftrebuilders.com.au

31-35 Cottage Street
Blackburn Vic 3130
Ph: 03 9894 0000 Fax: 03 9894 0011



“ SHE WAS SO SWEET,
SO PERFECT. STILL IS.”



The passion, the pride of ownership, the sheer emotional attachment – no one understands it better than Shannons. So when it comes to insurance for your special car, daily drive, bike or even your home, there's only one person you should talk to - a fellow enthusiast at Shannons. So call Shannons for a quote on 13 46 46.



SHARE THE PASSION

INSURANCE FOR MOTORING ENTHUSIASTS | CALL 13 46 46 FOR A QUOTE | SHANNONS.COM.AU

Shannons Limited is an authorised representative of Australian Alliance Insurance Company Limited, the issuer of this product. Refer to the Product Disclosure Statement by calling 13 46 46.